

ROTECH FOR RELIABILITY!

Why Accept Anything Less?



Installation – Mechanical - (If the shaft end cannot be drilled please refer to Magcon fixing shown below)

1. Select a suitable shaft to install the 'Rotech' unit to.
2. Use a 5mm drill to drill a pilot hole to a depth of 25mm into the centre of the end of the shaft.
3. Use a 10mm drill to open the hole to the required tapping size.

IMPORTANT

Take care that the shaft is drilled centrally.

4. Tap the 10mm X 25mm deep hole 12mm x 1-5.
5. Remove the rear cover the Motion Sensor/Encoder and using a 10mm Allen key wrench install the unit onto the shaft. Re-fit the rear cover.
6. Bolt the flexible securing strap to any convenient part of the machine frame work

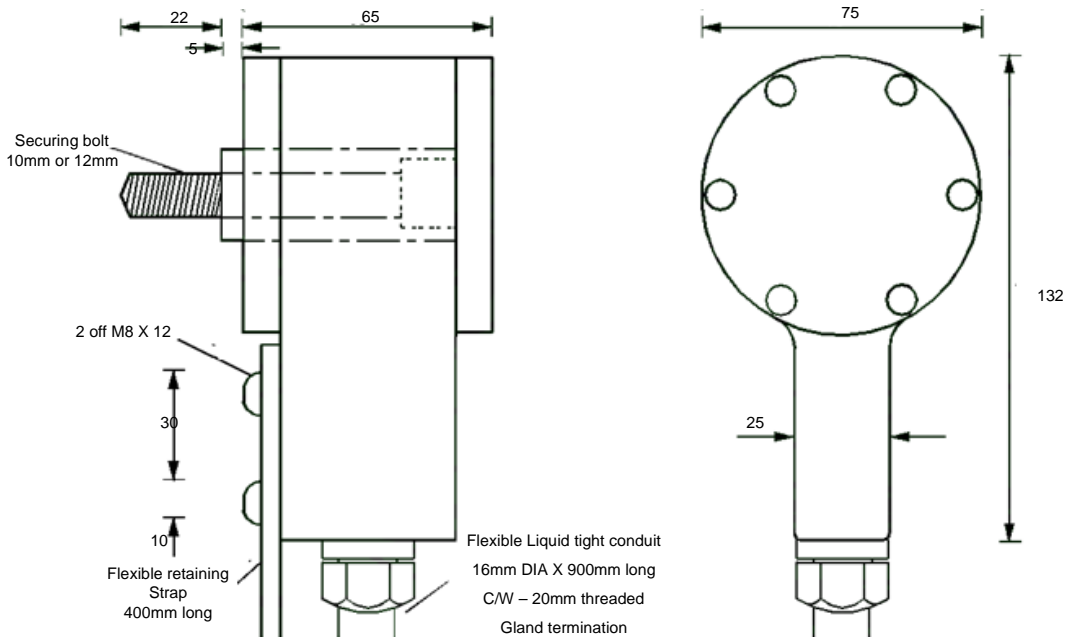

As an alternative method of securing the Rotech end of shaft unit without the need for drilling the shaft, our unique 'Magcon' unit can be used as shown below – see product data sheets for full details.

MAG-CON MAGNETIC CONNECTOR

For quick and easy installation of Rotech shaft mounted sensors & encoders

IMPORTANT NOTE:

MAXIMUM OPERATING SPEED IS 300RPM

RECOMMENDED MINIMUM

SHAFT DIAMETER FOR FITTING=35MM

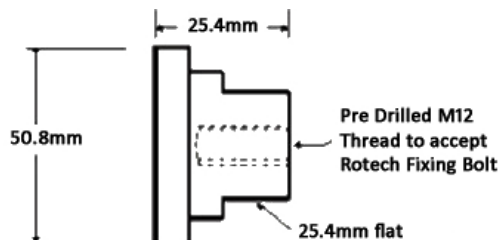

Commissioning & Testing

End of Shaft Mounted Encoders



Why Accept Anything Less?

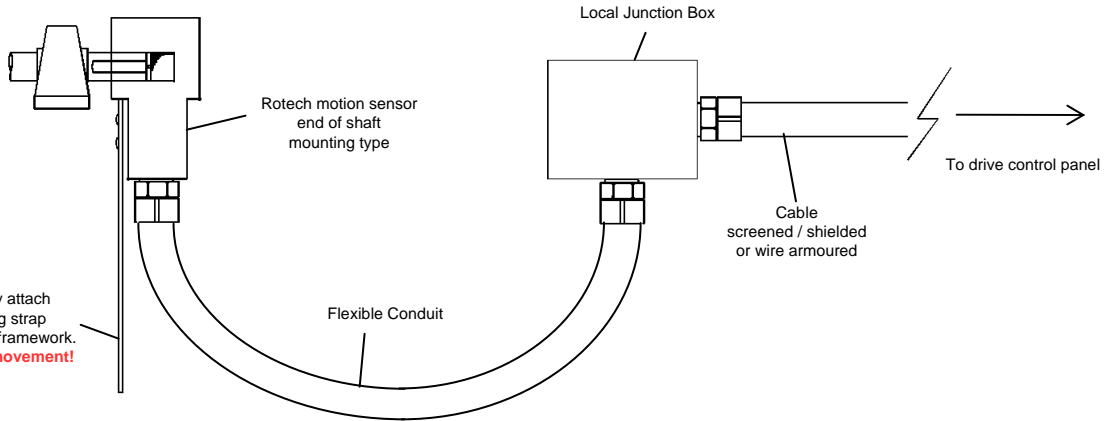

Installation

1. Drill & tap end of shaft to be monitored (refer to "Mag-con" data sheet for magnetic connector usage)
2. Remove rear cover plate from Rotech
3. Install Rotech to end of shaft using socket cap bolt provided. Ensure bolt does not 'bottom' in tapped hole, slippage may occur if shaft faces are not firmly in contact.
4. Refit rear cover plate to Rotech
5. If fitted - secure flexible restraining strap to convenient point on machine
6. Cable as per drawing above
7. Refer to appropriate Rotech data sheet for output type connections

Commissioning & testing

Important

All wiring must be in accordance with local and national electrical codes and should only be undertaken by an experienced and professional Qualified electrician.

All disconnections and connections must be made with the power supply switched off.

To test the Rotech unit it must be connected to it's power source and associated control circuit I.E. "Rotech" speed relay, plc, Computer, etc. And for power to be switched on.

Rotech sensor output type E, E2, E3

Connect a 0 to 30vdc voltmeter between brown and blue connections
Voltmeter should indicate D.C. Supply voltage of between 10 and 30vdc
Now Connect the voltmeter between the black and blue connections.
Rotate Rotech unit very slowly, voltmeter should indicate on/off pulses between 0vdc and the nominal Supply Voltage (Supply Voltage Minus 1 To 2 Vdc)

Rotech sensor type N

Connect a 0 to 10ma Multimeter in series with the blue wire connecting the Rotech unit to it's control circuit
rotate the Rotech unit very slowly, Multimeter should indicate on / off pulses of less than 1ma to greater than 3ma.
See note * 1 below

Rotech sensor type W

Connect a 0 to 240vac voltmeter between the brown connection and 0 vac, verify the supply voltage is present.
Now connect the voltmeter between the blue connection and 0 vac.
Rotate the Rotech unit very slowly, the voltmeter should indicate on / off pulses of between 0v and the supply voltage.
See note * 1 below

Note * 1

- * At higher speeds the meter will not respond quickly enough to the on / off pulses. It will display an average value between The max and min levels.
- * The number of on / off pulses for one complete revolution should be the same as detailed in the Rotech Product data sheets I.E. 1,10,120,360,500 etc.

Installation – Electrical

refer to page 2 for typical installation commissioning and testing information

1. Always complete the mechanical installation before commencing the electrical installation.
2. Install a suitable junction box within 300 – 600mm of the Motion Sensor/Encoder.
3. Gland – Off the flexible conduit of the Motion Sensor/Encoder in the junction box and connect the 2 or 3 wires to suitable terminals. (The flexible conduit and cable are supplied over-length they can be cut back and shortened as required)
4. Connect suitable wires and cable to route the Shaft Encoder signal back to the control panel.

Important

The maximum distance recommended between the Motion Sensor/Encoder and the control panel is 1000 yards.

Armoured or screened cable should be used if the cable is routed in the vicinity of power cables.

Do not route the Motion Sensor/Encoder signal through multi-core cables carrying other signals or voltages.

5. Alternative Installation

An alternative method of installation is to house the Control Module/Speed Relay etc. in a slightly larger terminal box.

A mains signal (typically 110Vac) can then be switched on by the control module and then routed via multi-cores; unprotected cables etc. back to the control panel.